

Lecture 1

September 27, 2023

Administrative Stuff: Instructors

- Instructor: Matt Bishop, mabishop@ucdavis.edu
 - Office Hours: MF2:10–3:00pm, W11:00–11:50am, in 2203 Watershed Sciences
 - When you send email, please put “ECS 235A” in the subject so I will know it is class related
- TA: Yongshuai Liu, yshliu@ucdavis.edu
 - Office Hours: Tu3:00–6:00pm, in 2231 Kemper Hall

Goals

- Understand what computer security is and learn its basic limits;
- Learn the basic policy models underlying security;
- Know about common vulnerabilities, the basics of software security and formal verification;
- Learn the basic techniques of cryptography;
- Learn about host-based security, network security, and intrusion detection; and
- Explore other topics of interest.

Class Information

- Textbook: M. Bishop, *Computer Security: Art and Science*, Second Edition, Addison-Wesley, Boston, MA (2019). ISBN 978-0-321-71233-2
- Web Sites
 - Canvas (this is the regular class web site)
 - <http://nob.cs.ucdavis.edu/classes/ecs235a-2023-04> (a backup web site)
- Grading
 - 50% Homework
 - 50% Project

Student Resources and No-Nos

- Resources:

<https://ebeler.faculty.ucdavis.edu/resources/faq-student-resources>

- Academic Integrity

<https://sja.ucdavis.edu/files/cac.pdf>

Projects

- You choose the project
 - Teams: up to 3 people; ask if you want more to join
- Due:
 - Mon Oct 9: topic and team composition
 - Fri Oct 27: background research
 - Nov 20: progress report
 - Last week of class: presentations (may be cancelled)
 - Tue Dec 12: completed projects

Outline

- Components of computer security
- Threats
- Policies and mechanisms
- The role of trust
- Assurance
- Operational Issues
- Human Issues

Basic Components

- Confidentiality
 - Keeping data and resources hidden
- Integrity
 - Data integrity (integrity)
 - Origin integrity (authentication)
- Availability
 - Allowing access to data and resources

Classes of Threats

- Disclosure
 - Snooping
- Deception
 - Modification, spoofing, repudiation of origin, denial of receipt
- Disruption
 - Modification
- Usurpation
 - Modification, spoofing, delay, denial of service

Policies and Mechanisms

- Policy says what is, and is not, allowed
 - This defines “security” for the site/system/*etc.*
- Mechanisms enforce policies
- Composition of policies
 - If policies conflict, discrepancies may create security vulnerabilities

Goals of Security

- Prevention
 - Prevent attackers from violating security policy
- Detection
 - Detect attackers violating security policy
- Recovery
 - Stop attack, assess and repair damage
 - Continue to function correctly even if attack succeeds

Assumptions and Trust

- Underlie *all* aspects of security
- Policies
 - Unambiguously partition system states
 - Correctly capture security requirements
- Mechanisms
 - Assumed to enforce policy
 - Support mechanisms work correctly

Types of Mechanisms

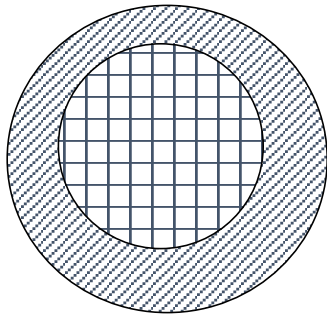

secure

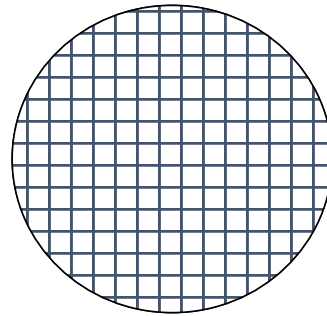

precise

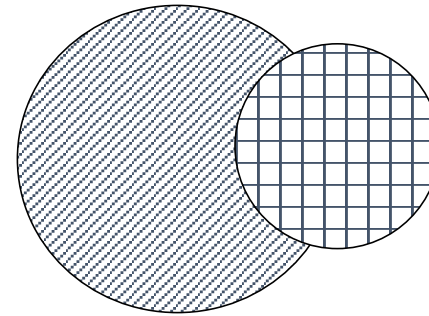

broad



set of reachable states



set of secure states

Assurance

- Specification
 - Requirements analysis
 - Statement of desired functionality
- Design
 - How system will meet specification
- Implementation
 - Programs or systems that carry out design

Example: SolarWinds

- SolarWinds provides widely used system management tools for network and infrastructure monitoring
 - Among the components is Orion, a performance monitoring system
 - Orion is used by over 30,000 public, private organizations, including government
- Attackers compromised system with Orion source code
- They then altered the source to create a back door
- At next upgrade of Orion, the rigged program was distributed
 - This gave the attackers access to organizations' infrastructure
- FireEye spotted infected customers' systems, then found they had been infected

Operational Issues

- Cost-benefit analysis
 - Is it cheaper to prevent or recover?
- Risk analysis
 - Should we protect something?
 - How much should we protect this thing?
- Laws and customs
 - Are desired security measures illegal?
 - Will people do them?

Human Issues

- Organizational problems
 - Power and responsibility
 - Financial benefits
- People problems
 - Outsiders and insiders
 - Social engineering

Tying Together

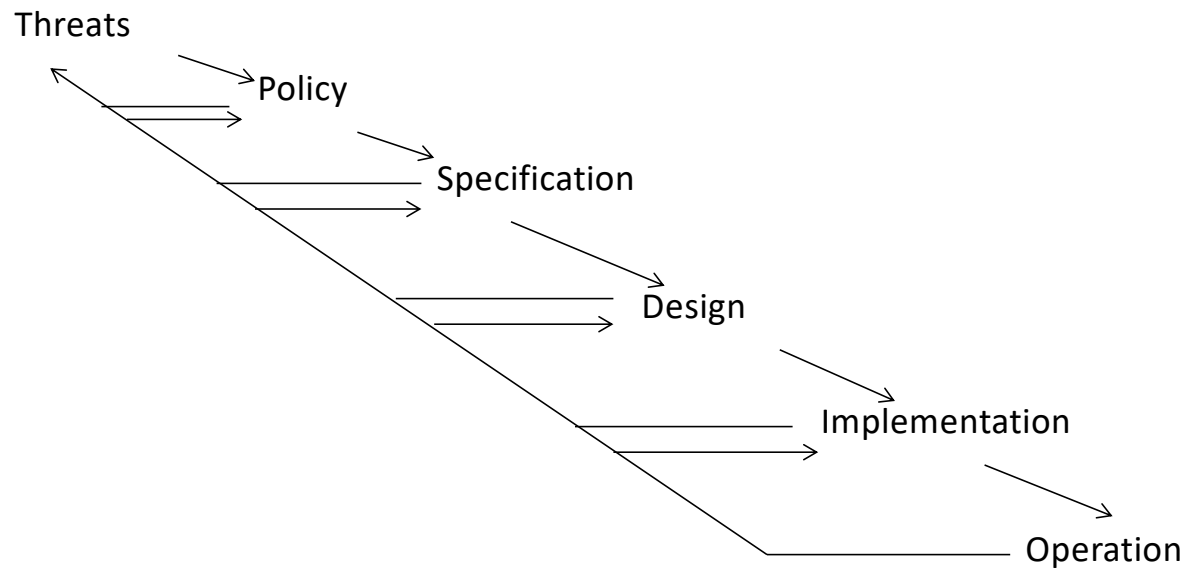

Key Points

- Policy defines security, and mechanisms enforce security
 - Confidentiality
 - Integrity
 - Availability
- Trust and knowing assumptions
- Importance of assurance
- The human factor